

5. Calculate the area of the rectangle below if its perimeter is 32cm



**THE MATHEMATICAL ASSOCIATION
OF NIGERIA (MAN)
(LAGOS STATE)**



2023 OLYMPIAD

CATEGORY: **PRIMARY**

DATE: 13th MAY, 2023

TIME: 1½hrs

Instructions:

1. This paper consists of two parts; PART A and PART B. Answer all the questions in each part.
2. The use of CALCULATORS or any ELECTRONIC DEVICES and STATISTICAL TABLES are not allowed.
3. Make sure your invigilator signs your answer booklet.
4. There is NO PROVISION for any *extra* answer sheet. Do not tear any part of your answer booklet.
5. Write your NAMES, your SCHOOL and your EXAMINATION number correctly on each page of your answer booklet.
6. CLARITY, NEATNESS and ORDERLINESS are highly encouraged.
7. Check your result with your Olympiad registration pin on www.manlagosstate.com from **Monday, June 12, 2023.**

DO NOT OPEN UNTIL YOU ARE TOLD TO DO SO

PART A

1a. An eight sided polygon is called a/an _____

b. Find the sum of the first positive prime numbers.

2a. Simplify: $\frac{0.04 \times 2.4}{8 \times 0.06}$

b. Find the sum of the HCF and LCM of 5, 7 and 9.

3a. If 20% of Pastor Ilesanmi's retirement salary is N64,480:00. What is 50% of his salary?

b. Dr. Akudo sold an article for N750.00 and made a profit of 50%. How much did he buy the article?

4a. If $2P_4 = 15P_9$. Find the value of P .

b. A goat costs 7 times as much as a hen. For N84, 000.00, I can buy 18 more hens than goats. How much does a goat cost?

b. Twice a certain positive number increased by 15 is the same as 55 less than three times the same number. Find half of the number.

5a. Add 10111_{two} , 111_{two} and 111011_{two}

b. Simplify: $\frac{x^2 - y^2}{x - y}$

PART B

1. Find the area of the equilateral ABCD, where $AC=22\text{cm}$, $BM=3\text{cm}$, $DN=3\text{cm}$ and $BM \perp AC$, $DN \perp AC$.

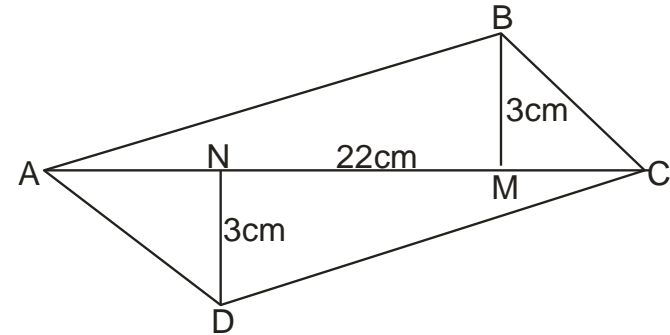

2. The average of $x + 6$, $x - 2$, $x + 3$, $x + 2$, $x - 1$, $x + 3$, $x + 4$ and $x - 5$ is 10. Find the range of the set of numbers.

3. Mrs. Okoilu borrowed some amount of money at simple interest. The rate of interest for the first 3 years was 5%, for the next 2 years was 8% and for the next 4 years was 10%. Beyond this, it was 12% per annum. If she paid N8, 560.00 as an interest for 12 years, how much did she borrow?

4. Iyanuoluwa travels 52km at a certain speed. She then decides to increase her speed by 5km to enable her reach her destination 72km away on time. If the time taken for both parts of the journey is the same, calculate her speed for the second part of the journey.

PTO

5. The sides of the parallelogram in the diagram below are given in cm. Calculate the area of the parallelogram.

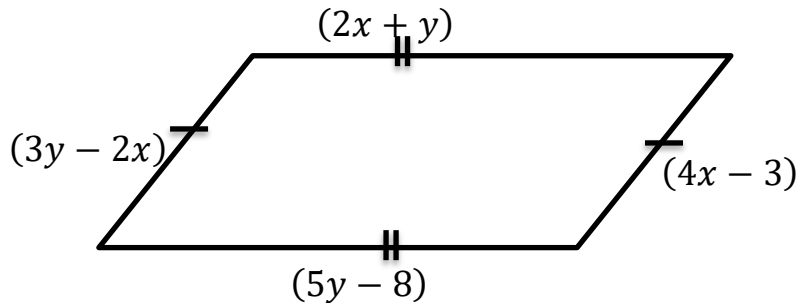

THE MATHEMATICAL ASSOCIATION
OF NIGERIA (MAN)
(LAGOS STATE)



2023 OLYMPIAD

CATEGORY: **JUNIOR**

DATE: 13TH MAY, 2023

TIME: 2hrs

Instructions:

1. This paper consists of two parts; PART A and PART B. Answer all the questions in each part.
2. The use of CALCULATORS or any ELECTRONIC DEVICES and STATISTICAL TABLES are not allowed.
3. Make sure your invigilator signs your answer booklet.
4. There is NO PROVISION for any *extra* answer sheet. Do not tear any part of your answer booklet.
5. Write your NAMES, your SCHOOL and your EXAMINATION number correctly on each page of your answer booklet.
6. CLARITY, NEATNESS and ORDERLINESS are highly encouraged.
7. Check your result with your Olympiad registration pin on www.manlagosstate.com from **Monday, June 12, 2023**.

DO NOT OPEN UNTIL YOU ARE TOLD TO DO SO

PART A

1a. Evaluate: $(17.57)^2 - (12.43)^2$

b. Find the simple interest paid on N280:00 at 9% per annum for 2years 6month.

2a. If $x^y = y^x$, prove that $\left(\frac{x}{y}\right)^{\frac{x}{y}} = x^{\left(\frac{x-y}{x}\right)}$

b. A fair six sided die is throws once. What is the probability of obtaining a prime number?

3a. Simplify and leave your answer in standard form

$$\sqrt{\frac{0.18 \times 12.5}{0.05 \times 0.2}}$$

b. Mrs. Akinpajo gained 12% after selling an article for N56.00. How much did she gain?

4a. A make-up pack which Mrs. Azeez-Olowu bought for N6, 000.00 and marked to give a profit 30% was reduced in a sales by 10%. Find the percentage profit.

b. The volume of a cylinder is 369m^3 . If the height of the cylinder is 14m. Find the value of the radius of the circular base of the cylinder. (Take $\pi = \frac{22}{7}$)

5a. Convert 11.011_{two} to a number in base ten.

b. Evaluate:

$$\frac{3\frac{1}{4} + \frac{1}{5}}{\frac{3}{4} \times 1\frac{1}{5} + 1\frac{2}{5}} \div \frac{4}{1 + \frac{2}{1 + \frac{3}{2+1}}}$$

PART B

1. A train leaves Ebute-Meta station at 5am and reaches Ibadan station at 10am on the same day. Another train leaves Ibadan station at 7am and reaches Ebute-Meta station at 2pm on the same day. Calculate the time at which the two trains meet?

2. Solve the simultaneous equation: $3x = 21 + 2y$ and $4y + 5x - 5 = 0$

3. Three books and two pencils weigh 430g and one book and four pencils of the same size as the first set weigh 210g. Find the weight of one book and one pencil.

4. Three traders took $(124 + x)$ oranges to market in ratio $2 : x : 3$. If the first trader took 36 oranges, how many oranges did the second farmer take to the market?

3. When a polynomial $f(x) = (p - 1)x^3 + px^2 + qx + r$ where p, q and r are constant is divided by $(x + 2)$ and $(x - 1)$ and the remainders are -5 and 4 respectively. If $(x + 1)$ is a factor of $f(x)$, find the zeros of $f(x)$.
4. On a certain day in my life, I spent 70% eating, 50% reading and 40% watching movies. At a time, I did two activities together; 30% eating and reading, 30% reading and watching movies, while I spent 20% eating and watching movies. If an activity is to be selected at random, what percentage of my day did I use in the doing the three activities together?
5. Let n be a natural n such that $n \geq 2$. Show that

$$\frac{1}{n+1} \left(1 + \frac{1}{3} + \frac{1}{5} + \dots + \frac{1}{2n+1} \right) > \frac{1}{n} \left(\frac{1}{2} + \frac{1}{4} + \frac{1}{6} + \dots + \frac{1}{2n} \right)$$



**THE MATHEMATICAL ASSOCIATION
OF NIGERIA (MAN)
(LAGOS STATE)**



2023 OLYMPIAD

CATEGORY: **SENIOR**

DATE: 13th MAY, 2023

TIME: 2hrs

Instructions:

1. This paper consists of two parts; PART A and PART B. Answer all the questions in each part.
2. The use of CALCULATORS or any ELECTRONIC DEVICES and STATISTICAL TABLES are not allowed.
3. Make sure your invigilator signs your answer booklet.
4. There is NO PROVISION for any *extra* answer sheet. Do not tear any part of your answer booklet.
5. Write your NAMES, your SCHOOL and your EXAMINATION number correctly on each page of your answer booklet.
6. CLARITY, NEATNESS and ORDERLINESS are highly encouraged.
7. Check your result with your Olympiad registration pin on www.manlagosstate.com from **Monday, June 12, 2023**.

DO NOT OPEN UNTIL YOU ARE TOLD TO DO SO

PART A

1a. Let $f: R \rightarrow R$ be defined by $f(x) = x^2 + 2x + 1$. Find the image of $f(-2)$.

b. Complete the below correctly:

θ	0°	30°	60°
sin	0		
cos	1		
tan	0		1

2a. Express: $\frac{y-25}{\sqrt{y+5}}$ in its simplest form.

b. Calculate the coefficient of x^4 in the expansion of

$$\left(x^2 - \frac{2}{x}\right)^5$$

3a. Find the value of x if

$$\log_{10} x + \log_{10} x^2 + \log_{10} x^4 + \log_{10} x^8 + \log_{10} x^{16} = 31$$

b. Find the square root of $31 + 4\sqrt{21}$

4a. If $\sin x = \frac{\sqrt{3}}{2}$, find the value of $\frac{\sin x}{\operatorname{cosec} x}$

b. Evaluate: $\int_0^{\frac{\pi}{2}} \cos 2x dx$

5a. The diagram below shows a right-angled triangle with sides of length 5cm, 12cm and 13cm. What is the radius of the inscribed semicircle whose base lies on the side of length 12cm?

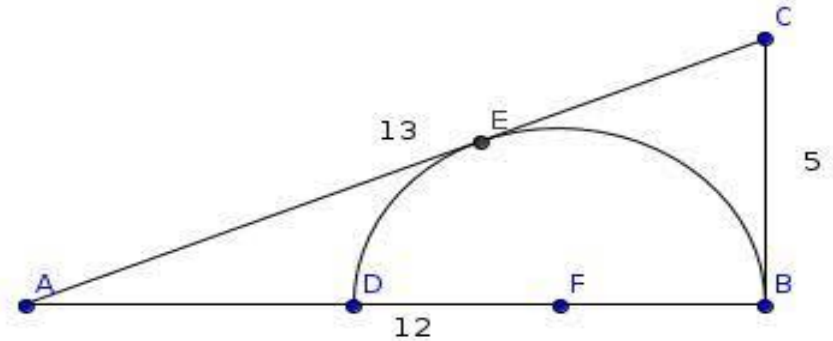

b. The operation $*$ on the set R of real number is defined as $x * y = \frac{2x+2y+1}{2}$ for $x, y \in R$. Calculate the identity element.

PART B

1. Find the solution to the system of equations:
 $y - \log_8(x + 2) = 1$ and $2 - y = \log_8 x$

2. Resolve $\frac{x^3}{(x-1)(x^3-1)}$ into partial fraction